



# Instruction Manual

## Shaker Accessories



## TABLE OF CONTENTS

---

Warnings	1
Universal, Dedicated and Culture Style Platforms	2
Adjustable Platforms and Large Vessel Carriers	3
Separatory Funnel Platform	3
Tier Braces	4
Test Tube Racks - Pivoting (Full Size)	5
Test Tube Racks - Stationary (Full Size)	5
Test Tube Racks - Stationary (Half Size)	6-7
Flask Clamps	8
Microplate Clamp	9

### WARNINGS

---



**CAUTION!** Install platforms on to shakers before adding flask clamps, test tube racks or other accessories. Two people may be needed for installation of extra large and jumbo platforms.



**CAUTION!** When using platform accessories, tighten mounting screws periodically. If excessive noise occurs while running unit, stop immediately and check mounting screw tightness.

**PLEASE NOTE:** Unit must be in standby mode before any platforms or accessories are attached to the shaker.

### WARRANTY

---

Manufacturer warrants this product to be free from defects in material and workmanship when used under normal conditions for five (5) years. Register your equipment of instrument online at [www.vwrsp.com/warranty](http://www.vwrsp.com/warranty) for US residents or [www.vwrcanlab.com/warranty](http://www.vwrcanlab.com/warranty) for Canadian residents. For your reference, make a note of the date of purchase and supplier here.

Date of Purchase: \_\_\_\_\_

Supplier: \_\_\_\_\_

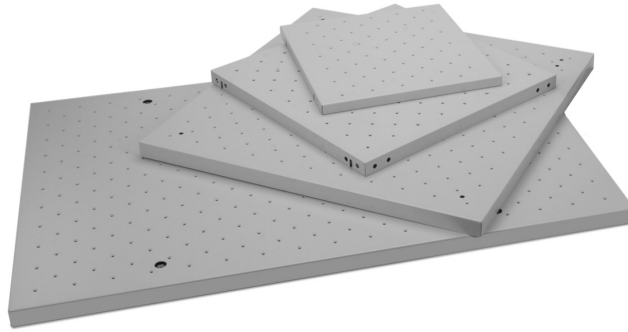

### **UNIVERSAL, DEDICATED AND CULTURE STYLE PLATFORMS**

---

For basic attachment of the platform to the shaker's tray, please refer to the installation instructions below for your specific model.

#### **1. Installation of Platforms for Models 3500, 3750 and 5000**

The black mat does not have to be removed from the shaker tray. Loosen the four (4) screw knobs on the shaker tray approximately  $\frac{1}{4}$ ". Place platform on shaker tray by aligning the slots on the two (2) sides of the platform over the four (4) screw knobs. Allow the platform to rest on the screws. When aligned and seated on the screws, hand-tighten the four (4) knobs. **DO NOT** over tighten.

**Please note:** Accessories larger than 13 x 13" will have two (2) flanges with slots on the underside of the platform. Align the slots over the knobs and hand tighten from the under side of the platform.

#### **2. Installation of Platforms for Models 10000 and 15000**

Before mounting the platform, remove the mat from the shaker's tray to expose the four (4) threaded openings. Hold the accessory platform from the outside and align the platform over the threaded openings on the tray. Place the accessory platform over the shakers' tray noting the four (4) threaded openings. Use a Phillips head screwdriver to tighten the integrated screws to the mounting holes in the shakers tray. **DO NOT** over tighten.



### ADJUSTABLE PLATFORMS AND LARGE VESSEL CARRIERS

---

#### Package Contents

- (1) Platform for mounting bars
- (4) 18" padded bars
- (8) Screw knobs

Adjustable Platforms and Large Vessel Carriers are mounted to the shaker tray in the same manner as the other platforms. The adjustable bars will require minor assembly. Place the bar in the desired location across the platform so the threaded end is resting in the open slots of the platform. Screw the knob to each end of the bar to secure. Repeat with the remaining bars.

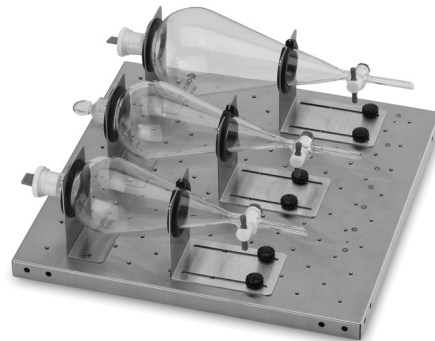

### SEPARATORY FUNNEL PLATFORM

---

#### Package Contents

- (1) 18 x 18 universal style platform
- (3) Pair of separatory funnel clamps
- (6) 10-32 x 1/2" phillips pan head screws
- (6) Screw knobs

Separatory Funnel Platforms are mounted to the shaker tray in the same manner as the other platforms. To secure the separatory funnel clamps, line up the openings in the clamp pairs with the openings in the platform that is appropriate for your funnel. Use the pan head screws for the shorter clamp. Set the funnel in place. Line up the longer clamp after placing the tapered neck into the opening. Use the screw knobs to secure in place.



---

## TIER BRACES

### Package Contents

- (4) Tier braces
- (32) 1/4-20 x 3/4" hex head screws
- (32) 1/4-20 jam hex head nuts

Align the tier brace's mounting holes to the mounting holes on the platform. The brace should be on the outside of the platform. Place a hex screw through the brace and platform. Place the hex nut on the end of the screw and tighten. A 7/16" socket wrench can be used to aid in tightening the nut. Attach the other three (3) braces to the same platform before securing to the second platform.

Attach all four (4) braces to the second platform. After the two (2) platforms are secured to the four (4) braces, secure to the shaker's tray following the instructions in the Platform Installation section (page 2).



### **PIVOTING - FULL SIZE** (not for use on Mini Shakers)

---

#### **Package Contents**

- (4) 10-32 x 5/16" flat head phillips screw
- (1) Adjustable angle stainless steel rack holder (2 piece)
- (1) Test tube rack (removable)

A Universal Platform is required in order to secure the rack to the shaker.

Line up the four (4) openings on the bottom of the outer rack with the four (4) compatible openings on the Universal Platform. Secure with the four (4) screws provided. If a tilt angle is desired, loosen wing knobs, tilt inner holder and tighten knobs. To maximize the platform's capacity for holding racks in the stationary position, remove the outer holder and secure the inner holder to the Universal Platform using the four (4) openings on the bottom of the inner holder.



### **STATIONARY - FULL SIZE** (not for use on Mini Shakers)

---

#### **Package Contents**

- (2) Mounting knobs
- (2) Washers
- (1) Test tube rack

A Universal Platform is required in order to secure the rack to the shaker. Universal Platforms must be 18 x 18" or larger.

Line up the two (2) openings on the sides of the test tube rack with the two (2) compatible openings on the Universal Platform. Place the washer on top of the opening on the test tube rack, place the clamp knob through the washer and rack, and hand tighten the clamp knob to the platform. Universal Platforms must be 18 x 18" or larger.

## TEST TUBE RACKS (CONT'D)

---

For basic attachment of the platform to the shaker's tray, please refer to the installation instructions below for your specific model.

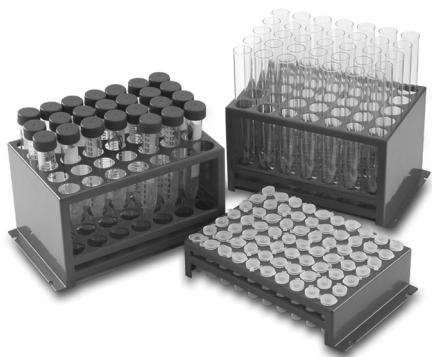

## STATIONARY - HALF SIZE

---

The hardware used depends on the shaker's tray or platform. Not all hardware will be used. See below for your specific shaker:

### Package Contents

- (2) Brackets (not needed when attaching to a Mini Shaker)
- (4) 10-32 x 3/8" pan head Phillips screw

- (2) 10-32 x 3/16" pan head Phillips screw
- (1) Test tube rack

### 1. Open Air Mini Shakers

USE: (2) 10-32 x 3/16" pan head phillips screws

Looking at the rack, the clip will be on the left and the slot opening will be on the right. Line up the slots on the rack with the openings on the platform and use the (2) 3/16" screws to secure. The clip will press into the side of the shaker's tray.

### 2. Incubating Mini Shakers

No hardware is required to secure the rack to the shaker's tray.

Line up the side of the rack, without the clip, to the shaker's tray. The clip will press in to the other side of the shaker's tray.

## TEST TUBE RACKS (CONT'D)

For basic attachment of the platform to the shaker's tray, please refer to the installation instructions below for your specific model.

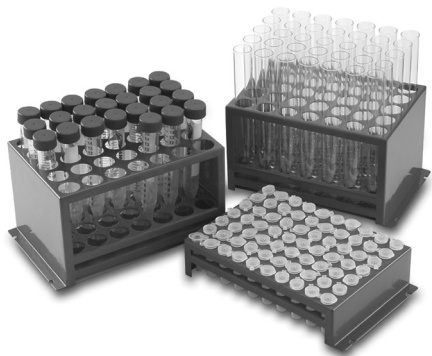

## STATIONARY (HALF SIZE)

### 3. Full Size Shakers (Model 3500, 3750, 5000, 10000 and 15000)

A Universal Platform is required in order to secure the rack to the shaker.

USE: (2) Brackets

(4) 10-32 x 3/8" pan head phillips screws

Place the two (2) brackets on the Universal Platform approximately 7 3/4" apart with the openings in the bracket against the platform and the side on the inside, next to where the rack will sit (see illustration). Align all four (4) openings with four (4) compatible openings in the platform. Using the four (4) 3/8", secure to the platform. When mounting the rack, place the side without the clip in first and then push down on the side with the clip. The clip should give you the tension you need to secure or remove the rack. If is it too tight or too loose, bend the clip accordingly.

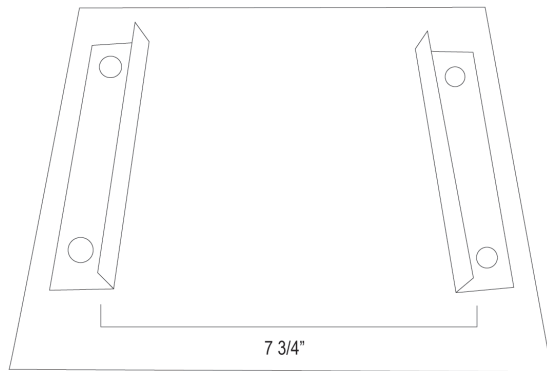





### FLASK CLAMPS (STAINLESS STEEL)

---

#### Package Contents

- (1) Flask or bottle clamp
- (1) 10-32 x 5/16" flat head phillips screw (for 10mL through 500mL)
- (5) 10-32 x 5/16" flat head phillips screws (flask clamps 1L and larger)
- (1) Extension spring (clamps 50mL and larger)

Line up the opening(s) in the clamp to the openings in the platform. Hand tighten screw(s) with a Phillips head screwdriver. Insert the flask or media bottle into the clamp and wrap the supplied spring around the neck of the flask to hold secure.



### FLASK CLAMPS (PVC COATED)

---

#### Package Contents

- (1) Flask clamp
- (3) 10-32 x 5/16" flat head slotted screws
- (3) ID 7/32" x OD 3/8" washers

Line up the opening(s) in the clamp to the openings in the platform. Hand tighten the screw(s) on top of the washer with a flat head screwdriver. Insert the flask into the clamp.

## MICROPLATE CLAMP

---



## MICROPLATE CLAMP

---

### Package Contents

- (1) Microplate clamp
- (2) 10-32 x 3/8" phillips pan head screws

Line up the openings in the clamp to the openings in the platform. Hand tighten the screws. Insert the microplate into the clamp.



---

MANUFACTURED BY:

**TROEMNER, LLC**

201 Wolf Drive • PO Box 87 • Thorofare, NJ 08086-0087  
Phone: 856-686-1600 • Fax: 856-686-1601 • E-mail: [troemner@troemner.com](mailto:troemner@troemner.com)  
[www.troemner.com](http://www.troemner.com)

715069-00 (REV 4 - 8/16)